

## CW-5000 Series industrial circulating chiller

### Contents

Caution .....	1
Parts introduced .....	2
Installation .....	3
Peration and parameter adjustment .....	4
Flow alarm and output ports .....	7
Specifications .....	8
Simple troubleshooting .....	9

Thank you for use the machine in s&A Electromechanical Co.,Ltd. Please read the installation instructions carefully before installingand operating the own and properly kept it.

Using the installation instructions in this book is not a quality assurance. Correction of typographical errors, errors mentioned in the errata information, and product improvement, at any time made by the s&A Electromechanical Co., Ltd, explained without advance notice to be amended will be incorporated into reprint in using the installation instructions.

## Caution

### 1. Make sure that good contact power outlet and ground benign!

While the chiller, the average operating current is small, it is sometimes instantaneous operating current of up to 6 ~ 10 amps (AC110V power supply models are sometimes instantaneous operating current of up to 10 ~ 15 amps).

### 2. Make sure that the work of chiller voltage stability, normal!

As the refrigeration compressor to the power supply voltage more sensitive standard products my company's normal operating voltage of 200 ~ 250V (110V model is 100 ~ 130V). If you really need a wider operating voltage range and can be customized.

### 3. To protect the pump, water is strictly prohibited to run!

The new machine packing before they emptied the water storage tanks, make sure the tank water and then start, otherwise the pump easily damaged. And when the water level in the tank water level gauge green (**NORMAL**) range below the cooling mechanism for cooling capacity will be slightly lower, it is recommended to ensure the water level in the tank water level gauge green (**NORMAL**) range. Prohibited the use of circulating pump drain!

### 4. Please ensure that the chiller smooth passage into the wind out of the wind!

Chiller outlet from behind the barrier to be left out of 30 cm and the distance from the inlet side of the barrier required over a distance of 8 cm.

### 5. Into the outlet of the filter must be regularly cleaned!

Must be regularly take apart and wash dust network, dust-proof net chiller failure will cause a serious blockage.

### 6. Please note that the impact of condensed water!

When the water temperature below the ambient temperature, and humidity is larger, the cycle of water being cooled the surface of the device will produce condensate. When the above, it is recommended to increase the water temperature settings, or to the pipe insulation device being cooled.

### 7. Machines for staff!

The appliance is not to be used by children or persons with reduced physical, sensory or mental capabilities, or lack of experience and knowledge, unless they have been given supervision or instruction, children being supervised not to play with the appliance!

# Parts introduced



English

## Installation

Chiller installation is very simple, the new aircraft for the first time the following steps can be carried out.

1. Open the package, check the machine is intact, whether prepare all the necessary accessories.
2. Open-mouth screw-top water, add the cooling water.

Should observe the water level gauge water side of the water level in the side of slowly adding water, careful not to let the water overflow! For the carbon steel cooling equipment should be added an appropriate amount of anti-corrosion agents. The northern cold regions should be used in filling non-corrosive antifreeze.

3. Then according to equipment in a good outlet pipe, into the pipe.
4. Plug the power cord, turn the power switch. (Forbidden anhydrous boot!)

Open the power switch, the chiller circulation pump began to work. The first boot of new aircraft will be more bubbles in the pipeline leading to occasional machine flow alarm, run a few minutes later will be back to normal.

After the first boot, you must immediately check whether the water pipe leaks.

Power is turned on, if the water temperature below the set temperature, fan and other components the machine does not work is normal. Thermostat setting control parameters based on automatic compressor, battery valves, fans and other devices working condition.

As the compressor and other devices have a long boot process, according to different conditions ranging from tens of seconds to minutes, so do not frequently switch machines.

5. Check the radiator water level.

After the new aircraft start emptying the water in the air, water tank water level would decline, but in order to maintain the water level in the green area, adequate water again. Observe and record the water level of the current situation, such as chiller running again after a period of time observation of level gauge, if the water level dropped significantly, we should re-check the water pipeline leakage.

6. Adjust the temperature control parameters.

CW-5000-series smart thermostat generally do not need to adjust the control parameters, such as really necessary, may refer to page 4, "operational status and parameters to adjust."

## Peration and parameter adjustment

Under normal circumstances the new intelligent controller do not need to adjust the control parameters, it will automatically adjust according to changes in room temperature control parameters to ensure that equipment to meet the cooling requirements.

### 1. Refrigeration controller panel description

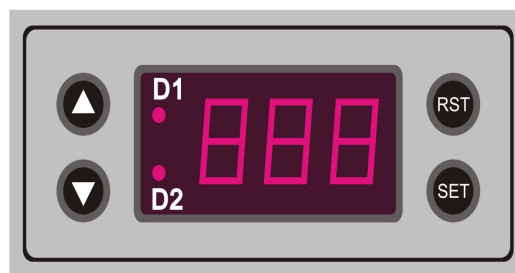

(1) Thermostat working state indicator **D1**、**D2** (pictured)

**D1** ON: Indicating controller work in intelligent control mode;

**D1** OFF: Indicating controller work in the constant temperature control mode;

**D1** FLASHES: Indicating controllers work in the parameter setting mode or display values for room temperature;

**D2** ON: Indicating controller working condition for refrigeration;

**D2** OFF: Directed the work of state controller, insulation;

(2) In the non-established state, press ▼ button will show the temperature at room temperature, 6 seconds to restore the default display. (At this point **D1** flashing, indicating that displayed at room temperature.)

(3) ▲ ▼ keys This to adjust the controller, display status, parameter selection and adjust it.

(4) **RST** key This to determine the key.

(5) **SET** key This to set function keys.

## 2. To restore factory settings

Pre-boot, press and hold then turn ▲▼ button until the controller displays rE. Release the button after 3 seconds the controller into the normal working condition. Then controller all parameters settings have been restored to factory settings.

## 3. Alarm function

Alarm display:

E1	E2	E3	E4	E5
Room temperature higher	Water temperature higher	Water temperature lower	Room temperature sensor failure	Water temperature sensor failure

The error code and the temperature will be alternately displayed when alarm.

In the alarm state can press any key to stop alarm sound, but the alarm until the alarm conditions which indicate the need to eliminate after the stop.

## 4. Thermostat control parameter list

Order	Code	Set Project	Range	Factory settings	Notes
1	F0	Set temperature	F8~F9	25	Constant temperature
2	F1	Temperature values	-15~+5	-2	Intelligent control
3	F2	Cooling hysteresis	0.2~3.0	0.8	
4	F3	Control	0~1	1	1 intelligent, 0constant
5	F4	Water temperature higher alarm	1~20	10	
6	F5	Water temperature lower alarm	1~20	15	
7	F6	Room temperature higher alarm	40~50	45	
8	F7	Password	00~99	08	
9	F8	Max water temperature	F9~40	30	Intelligent control
10	F9	Min water temperature	5~F8	20	Intelligent control

## 5. General settings to adjust

Press set button **(SET)** into the user-defined state, at this point **D1** flashes to indicate that the controller parameter setting status.

- (1) In the intelligent mode, the display of the temperature difference between water temperature and air temperature parameter values **(F1)**.
- (2) In the constant temperature mode, the display setting temperature value **(F0)**.

At this point press ▲ ▼ key to change settings, modify the value, press the confirm button **(RST)** save exit after the new parameters take effect. Such as press set key **(SET)** is not setting out to save the state parameters, such as the No button is pressed within 20 seconds, automatically exit without saving parameter changes state.

## 6. Advanced settings to adjust

- (1) Hold down the ▲ key while press set button **(SET)** 5 seconds to display 00, this time press ▲ ▼ button to select the password has been set, and then click the OK button **(SET)**, such as the password is correct, display to F0, enter the set state, **D1** flashes to indicate that the controller parameter setting status. Such as the password is incorrect, then the return to temperature display.
- (2) Set the state to enter circulation and press ▲ key to turn the project into the choice set, according to the opposite direction buttons ▼ circulation. Select the item and then click settings button set **(SET)**, proceed to the next level parameters modify, display the original settings, this time press ▲ ▼ key to modify parameter values, and then set the button **(SET)**, then return to the previous a layer of the menu settings item. Press OK button at any time **(RST)**, then save the modified parameter setting out the parameters of the state, return temperature display, and then run the new parameters. Within 20 seconds if no button is pressed, the controller will automatically exit parameter setting state, and does not save the modified parameters.

**Note:** In the parameter setting state, according to the original parameters of the system is running.

## Flow alarm and output ports

In order to ensure that the cooling water cycle does not affect the abnormal situation, the safety equipment, CW-5000 Series chillers unique low flow alarm protection.

### (1) Flow alarm output ports and the wiring diagram

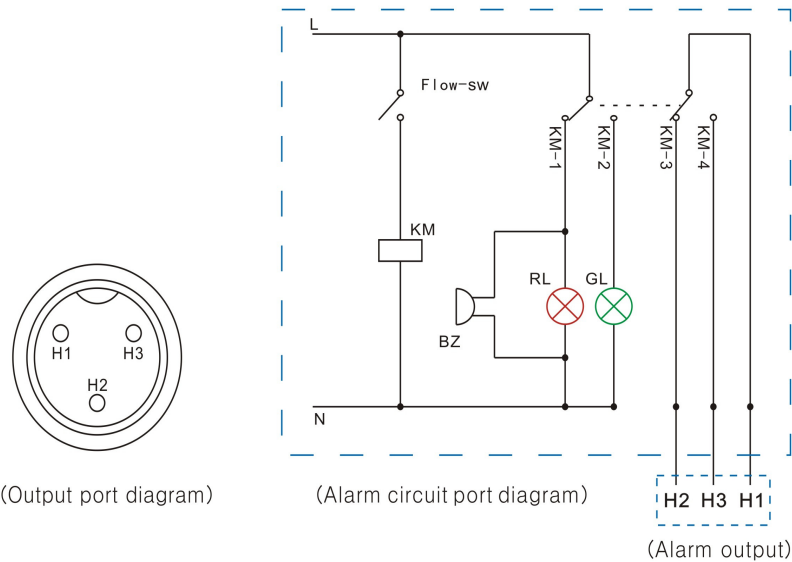

### (2) Circulating cooling water flow alarm causes and the work of the state table

	Normal flow indicator	Alarm flow indicator	Buzzer	Output ports H1, H2	Output ports H1, H3
Normal pump work	ON	OFF	NOT RING	OPENING	CONDUCTION
Plug the loop cooling water cycle	OFF	ON	RING	CONDUCTION	OPENING
Water alarm	OFF	ON	RING	CONDUCTION	OPENING
Circulating water pump failure	OFF	ON	RING	CONDUCTION	OPENING
Power interruption				CONDUCTION	OPENING

Note: The flow alarm relay port to connect the machine a group of normally open, normally closed contact. Required operating current is less than 5A, working voltage less than 300V.

## Specifications

### 1. CW-5000

Model	CW-5000AG	CW-5000BG	CW-5000DG	CW-5000AK	CW-5000BK	CW-5000DK
Voltages	AC220~240V	AC208~230V	AC100~110V	AC220~240V	AC208~230V	AC100~110V
Frequency	50Hz	60Hz	50/60Hz	50Hz	60Hz	50/60Hz
Current	1.4~2.1A		3.5~5.6A	1.4~2.1A		3.5~5.6A
Refrigerating output	2361Btu/h	2999Btu/h	2866Btu/h	2361Btu/h	2999Btu/h	2866Btu/h
Refrigerant	R-134a					
Rdfrigerant weight	300g	320g	280g	300g	320g	280g
Capacity	6L					
Inlet and outlet hold	Outside dimensions 10mm brass connector			Inside dimensions 8mm speedy connector		
Max pumping lift	10M			100M		
N.W	26Kg			29Kg		
G.W	31Kg			34Kg		
Dimensions	55 X 28 X 43 cm (LxWxH)					
Packing dimensions	71 X 41 X 62 cm (LxWxH)					

### 2. CW-5200

Model	CW-5200AG	CW-5200BG	CW-5200DG	CW-5200AK	CW-5200BK	CW-5200DK
Voltages	AC220~240V	AC208~230V	AC100~110V	AC220~240V	AC208~230V	AC100~110V
Frequency	50Hz	60Hz	60Hz	50Hz	60Hz	60Hz
Current	2.4~3.1A	2.6~3.3A	4.5~6.5A	2.4~3.1A	2.6~3.3A	4.5~6.5A
Refrigerating output	5084Btu/h	6295Btu/h	5186Btu/h	5084Btu/h	6295Btu/h	5186Btu/h
Refrigerant	R-22					
Rdfrigerant weight	360g	380g	350g	360g	380g	350g
Capacity	6L					
Inlet and outlet hold	Outside dimensions 10mm brass connector			Inside dimensions 8mm speedy connector		
Max pumping lift	10M			100M		
N.W	30Kg			33Kg		
G.W	35Kg			38Kg		
Dimensions	55 X 28 X 43 cm (LxWxH)					
Packing dimensions	71 X 41 X 62 cm (LxWxH)					

## Simple troubleshooting

Failure	Failure cause	Approach
No power	Power line contact with poor	Check the power outlet and the power cord plug whether the patch in place and good contact
	Fuse burn-out	Pull the machine power supply interface fuse box, check the fuse, if necessary, replaced with spare fuses, and check the power supply voltage is stable; check the power connector, power cord plug is patch in place, good contact
Flow alarm (panel red light)	Storage tank water level is too low (Directly connected with the water outlet, inlet, there is no water flow)	Check water level gauge display window, add water to the level shown in the green area; and check whether the leakage of water circulation pipe
	Water circulation pipes are blocked or a pipe bending deformation. (Directly connected with the water outlet, inlet, when there is water, not alarm)	Check water circulation pipe
Water temperature ultra-high alarm	Net plug dust, heat bad	Regular cleaning removed dust networks
	Insufficient ventilation	To ensure a smooth ventilation outlet and inlet.
	Voltage is very low or unstable	To improve the supply line or use the regulator
	Thermostat improper parameter settings	To re-set control parameters or restore the factory settings.
	Machines frequently switch	The refrigeration chiller to ensure there is sufficient time (five minutes or more)
	Excessive heat load	Reduce the heat load, or use a larger cooling capacity of the model
Room temperature ultra-high alarm	The machine using the ambient temperature too high	Improving the ventilation to ensure that the machine is running at 40 degrees below ambient temperature
Condensate serious condensation	Water temperature higher than ambient temperature, high humidity	Increase in water temperature or to pipe insulation
When changing the water the drainage outfall is slow	Injection port does not open	Open the injection port